

DS18[®]

OWNER'S MANUAL

MANUAL DEL USUARIO

SQT1

**1.3" MULTI-MOUNT PEI MINI DOME
TWEETER WITH 0.8" VOICE COIL**

TWEETER MINI DOMO PEI DE MONTAJE
MÚLTIPLE DE 1.3" CON BOBINA MÓVIL DE 0.8"

4Ω



ENGLISH | ESPAÑOL





1.3" MULTI-MOUNT PEI MINI DOME TWEETER WITH 0.8" VOICE COIL

TWEETER MINI DOMO PEI DE MONTAJE MÚLTIPLE
DE 1.3" CON BOBINA MÓVIL DE 0.8"

SPECIFICATIONS / ESPECIFICACIONES:

Nominal Diameter / Diámetro nominal	1.3" / 33mm
Nominal Impedance / Impedancia nominal	4 ohms
AES Power Handling / Manejo de potencia AES	15W
Program Power Handling / Manejo de potencia del programa	30W
Peak Power Handling / Manejo de potencia pico	60W
Sensitivity (1w/1m) / Sensibilidad (1w /1m)	92dB
Frequency Response / Respuesta de frecuencia	1KHz-20KHz
Recommended Hi Pass Crossover /	3KHz
Crossover de paso alto recomendado	
Pair / Single / Par / Unidad	Pair/ Par
Body Color / Material / Color / Material del Cuerpo	Black / ABS / Negro / ABS

MOTOR / MOTOR:

Voice Coil Diameter / Diámetro de la bobina de voz	0.8" / 20.4mm
VC Former Material / Material interior de bobina de voz	KSV
Winding Material / Material de bobinado	Copper / Cobre
Diaphragm Material / Material del diafragma	PEI
Magnet Material / Material del imán	Neodymium (N38H) / Neodimio (N38H)
Magnet Weight / Peso del imán	1.16 Oz



MEASUREMENTS WITH FLUSH MOUNT ADAPTOR /

MEDIDAS CON ADAPTADOR DE MONTAJE EMPOTRADO:

Overall Diameter / Diámetro total 1.75" / 45mm

Overall Depth / Profundidad total..... 1" / 25mm

Front Mount Baffle Cutout / Corte del orificio de montaje 1.6" / 40mm

Mounting Depth / Profundidad de montaje0.75" / 20mm

MEASUREMENTS WITH ANGLE SURFACE MOUNT ADAPTOR /

MEDIDAS CON ADAPTADOR DE MONTAJE SOBRE SUPERFICIE EN
ÁNGULO:

Overall Diameter / Diámetro total 1.3" / 33.5mm

Overall Height / Altura total 1" / 26.7mm

MEASUREMENTS FOR TWEETER WITHOUT ADAPTOR / MEDIDAS DE

TWEETER SIN ADAPTADOR:

Overall Diameter / Diámetro total 1.3" / 33.5mm

Overall Height / Altura total0.96" / 24mm

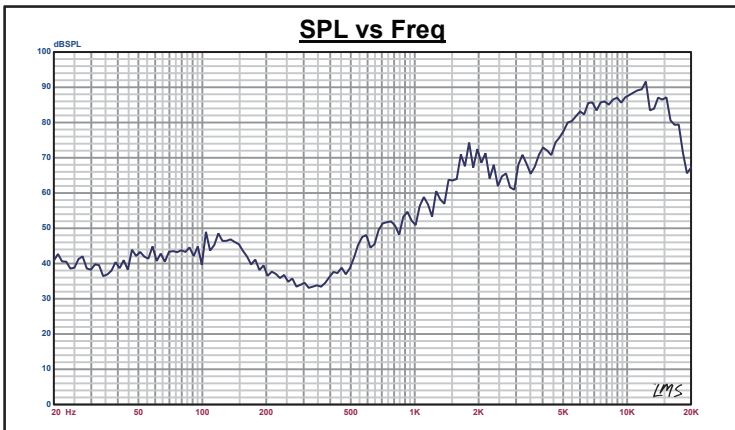

MEASUREMENTS WITH FLUSH MOUNT ADAPTORS /

MEDIDAS CON ADAPTADORES DE MONTAJE EMPOTRADO:

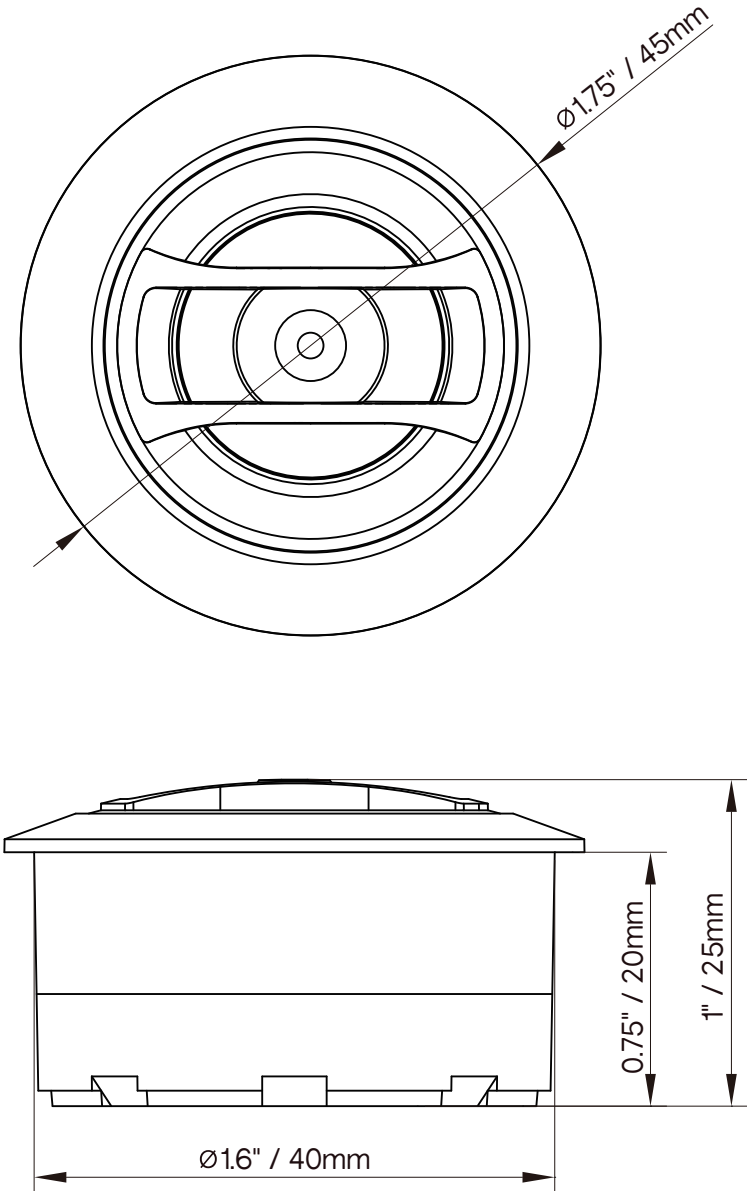

**MEASUREMENTS WITH ANGLE SURFACE MOUNT ADAPTORS /
MEDIDAS CON ADAPTADORES DE MONTAJE SOBRE SUPERFICIE
EN ÁNGULO:**

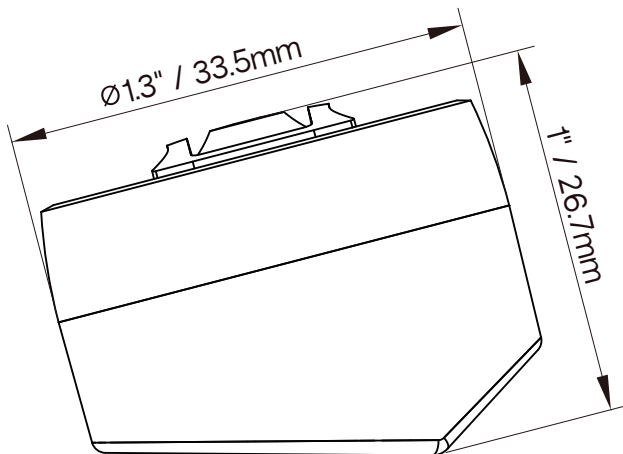
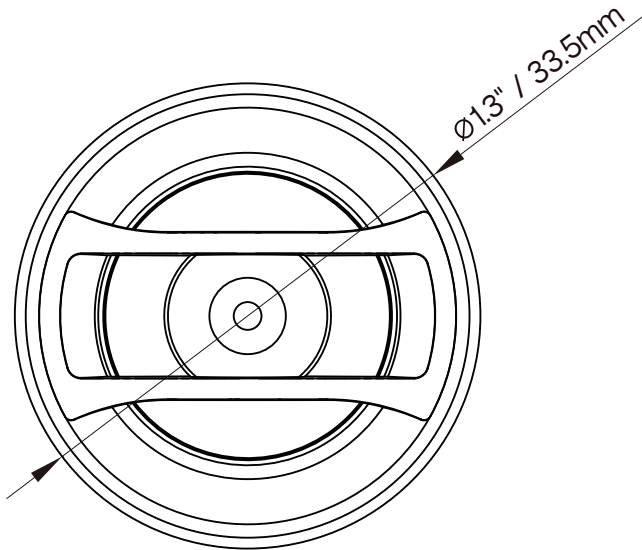

MEASUREMENTS FOR TWEETER WITHOUT ADAPTORS / MEDIDAS DE TWEETER SIN ADAPTADORES:

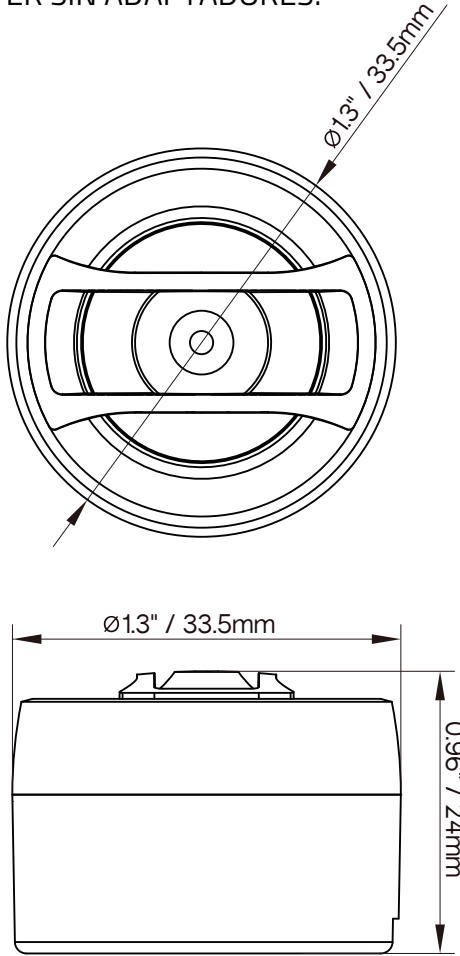

WARRANTY

Please visit our website DS18.com for more information on our warranty policy.

We reserve the right to change products and specifications at any time without notice. Images may or may not include optional equipment.



WARNING:
Cancer and Reproductive Harm.
www.P65Warning.ca.gov

GARANTÍA

Visite nuestra página web DS18.com para obtener más información sobre nuestra garantía.

Nos reservamos el derecho de cambiar productos y especificaciones en cualquier momento sin previo aviso. Las imágenes pueden incluir o no equipo opcional.



ADVERTENCIA:
Cáncer y Daño Reproductivo.
www.P65Warning.ca.gov



FOR MORE INFORMATION
PLEASE VISIT
DS18.COM

WE LIKE IT LOUD

The DS18 logo is rendered in a bold, black, stylized font. The "D" and "S" are connected, and the "18" is positioned to the right. A registered trademark symbol (®) is located at the top right of the "8".

DS18[®]