



# DS18<sup>®</sup>

PRO

OWNER'S MANUAL

PRO-W10.4S  
10" WOOFER  
LOUDSPEAKER  
WATER RESISTANT CONE



PERFECT FOR  
MOTORCYCLES



# PRO-W10.4S

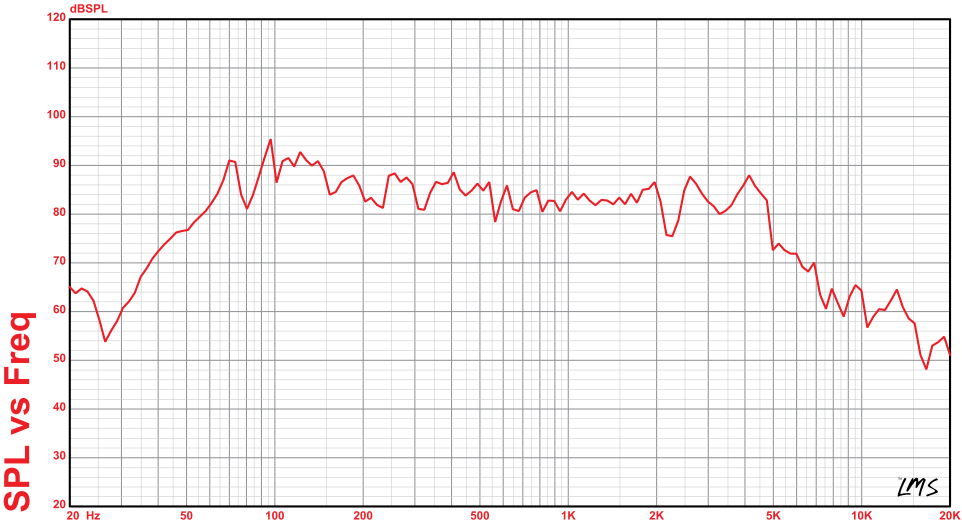
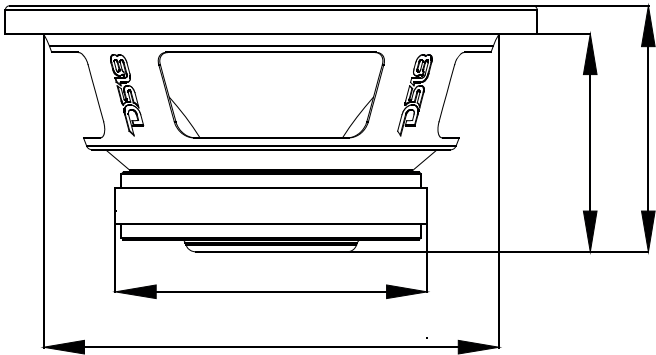
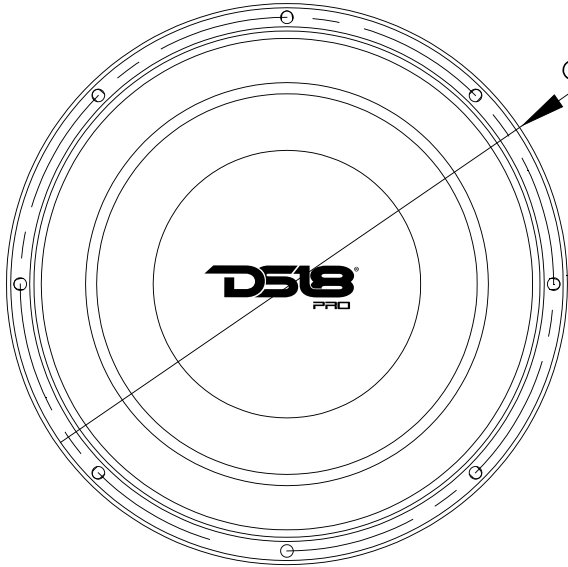



### Specifications:

Nominal Diameter .....	10" (254mm)
Nominal Impedance .....	4 ohms svc
Maximum Power Handling .....	700 watts
RMS Power Handling .....	350 watts
Sensitivity (1w/1m) .....	88 db
Frequency Response .....	40Hz-4.5KHz
Recommended Lo Pass Crossover .....	180hz

### Motor:

Voice Coil Diameter .....	2.5" (65.5mm)
Voice Coil Former Material .....	Til
Winding Material .....	SV
Cone Material .....	Water resistant paper
Dust Cap Material .....	Water resistant paper
Surround Material .....	Rubber
Basket Material .....	Steel
Magnet Material .....	Ferrite
Magnet Weight .....	46 oz
Displacement Volume .....	2.12L

### Thiele & Small Parameters:

Equivalent Volume.....	Vas	19.654 LTR
Free Air Resonance.....	Fs	40 Hz
Mechanical Factor.....	Qms	4.275
Electrical Factor .....	Qes	0.561
Total Factor.....	Qts	0.492
Moving Mass.....	Mms	67.313g
Compliance.....	Cms	0.23mm/N
BI Factor.....	BI	9.801
Voice Coil Inductance.....	Le	1.165mH
Diaphragm Area.....	Sd	0.035299sq/m
Dc Resistnace.....	Re	3.2 ohms
Efficiency Bandwith Product.....	EBP	77.2

### Measurements:

Overall Diameter .....	264 mm (10.39")
Overall Depth .....	128 mm (5.04")
Front Mount Baffle Cutout .....	231 mm (9.09")
Mounting Depth .....	114 mm (4.49")
Motor Diameter .....	156 mm (6.14")



FOR MORE INFORMATION  
PLEASE VISIT  
[DS18.COM](http://DS18.COM)

*WE LIKE IT LOUD*

The DS18 logo, consisting of the letters "DS18" in a bold, stylized, italicized font. The "D" and "S" are connected, and the "18" is slightly offset. A registered trademark symbol (®) is located to the upper right of the "8".

**DS18<sup>®</sup>**