



DS18[®]

PRO

OWNER'S MANUAL

PRO-W10.2SNEO
10" NEODYMIUM
WOOFER LOUDSPEAKER
WATER RESISTANT CONE



PERFECT FOR
MOTORCYCLES



PRO-W10.2SNEO

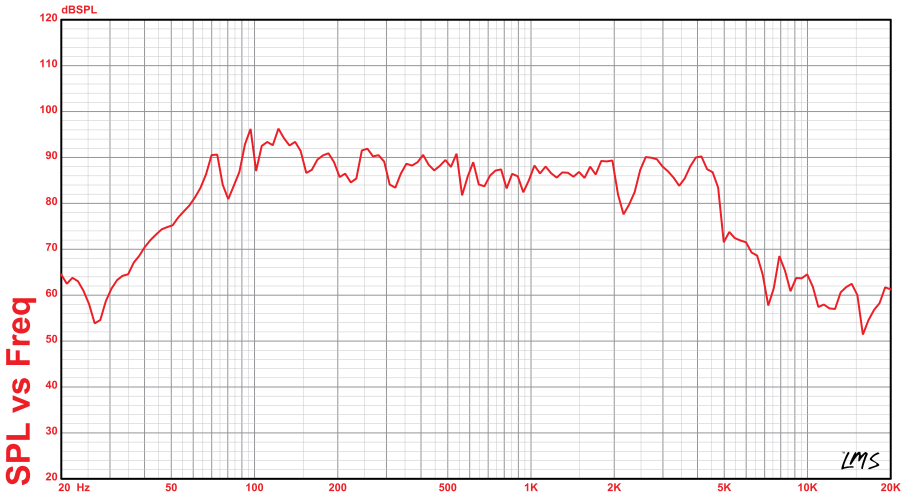
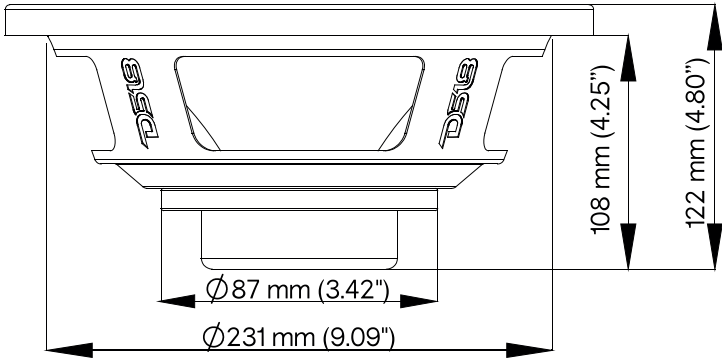
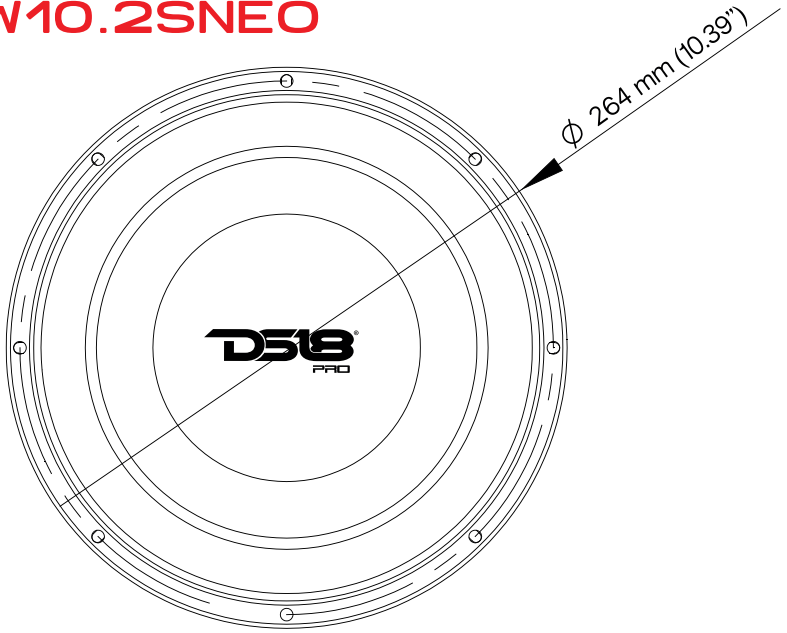



Specifications:

Nominal Diameter	10" (254mm)
Nominal Impedance	2 ohms svc
Maximum Power Handling	800 watts
RMS Power Handling	400 watts
Sensitivity (1w/1m)	91 db
Frequency Response	40Hz-5KHz
Recommended Lo Pass Crossover	180hz

Motor:

Voice Coil Diameter	2.5" (65.5mm)
Voice Coil Former Material	Til
Winding Material	SV
Cone Material	Water resistant paper
Dust Cap Material	Water resistant paper
Surround Material	Rubber
Basket Material	Steel
Magnet Material	Neodymium
Magnet Weight	8.8 oz
Displacement Volume	1.79L

Thiele & Small Parameters:

Equivalent Volume.....	Vas	22.514 LTR
Free Air Resonance.....	Fs	41.5 Hz
Mechanical Factor.....	Qms	5.846
Electrical Factor	Qes	0.452
Total Factor.....	Qts	0.397
Moving Mass.....	Mms	91.85g
Compliance.....	Cms	0.16mm/N
BI Factor.....	BI	12.95
Voice Coil Inductance.....	Le	0.4578mH
Diaphragm Area.....	Sd	0.035299sq/M
Dc Resistnace.....	Re	2 ohms
Efficiency Bandwith Product.....	EBP	91.8

Measurements:

Overall Diameter	264 mm (10.39")
Overall Depth	122 mm (4.80")
Front Mount Baffle Cutout	231 mm (9.09")
Mounting Depth	108 mm (4.25")
Motor Diameter	87 mm (3.42")



FOR MORE INFORMATION
PLEASE VISIT
DS18.COM

WE LIKE IT LOUD

The DS18 logo, consisting of the letters "DS18" in a bold, stylized, italicized font. The "1" is a vertical bar between the "S" and "8". A registered trademark symbol (®) is located at the top right of the "8".

DS18[®]