

The logo for DS18, featuring the letters 'DS18' in a bold, stylized font. The 'D' and 'S' are connected, and the '18' is separate. A registered trademark symbol (®) is located to the upper right of the '8'.

DS18[®]

OWNER'S MANUAL PRO-EXL104MB

10" MID-BASS LOUDSPEAKER 4 ohms

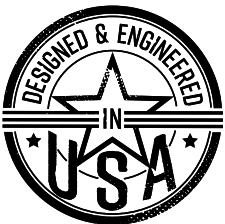
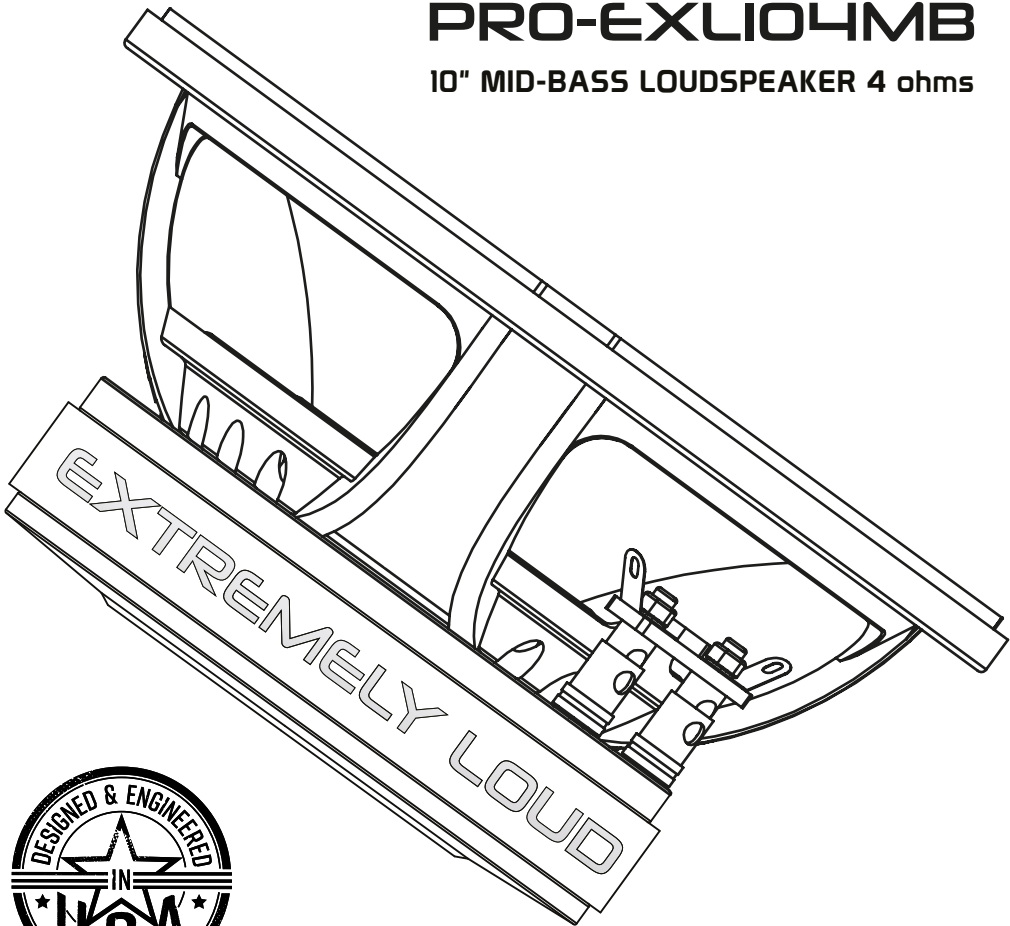

PRO-EXL104MB

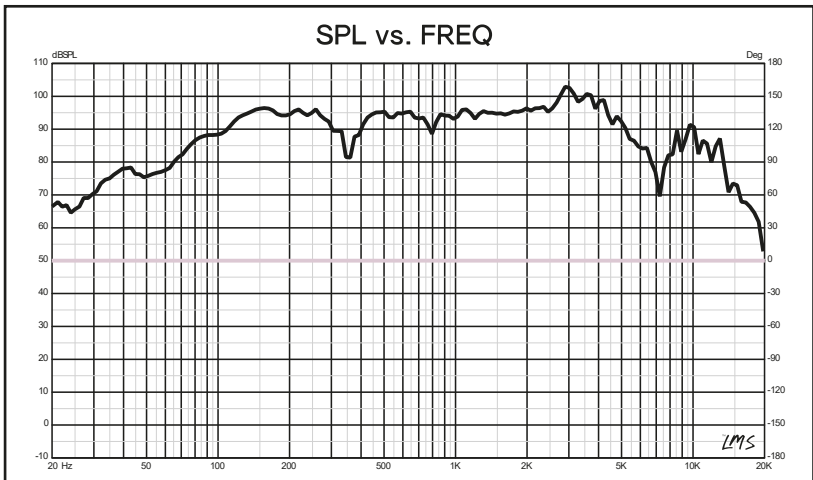
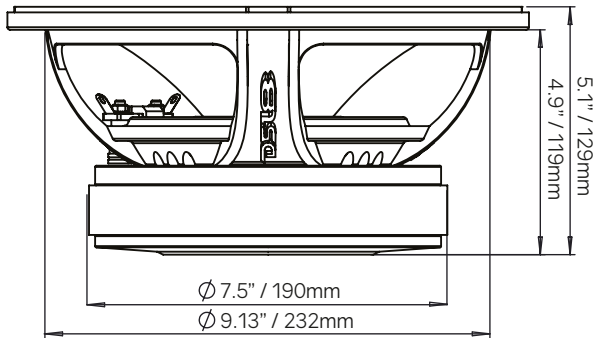
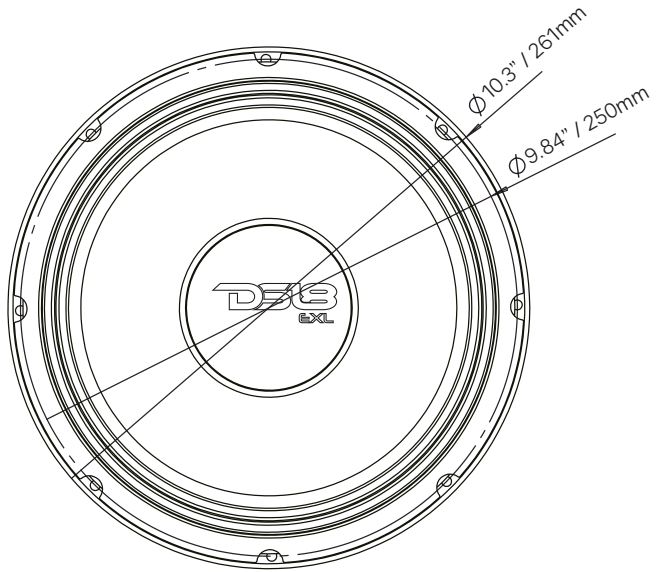

Specifications

Nominal Diameter	10"
Nominal Impedance	4 ohm
RMS Power Handling	600 Watts
MAX Power Handling	1200 Watts
Sensivity (1w/1m)	96dB
Frequency Response.....	72Hz-10.5KHz
Recommended HI Pass Crossover.....	80 Hz

Motor

Voice Coil Diameter.....	3" / 76.5mm
Voice Coil Former Material	Kapton
Winding Material	CCAW
Cone Material.....	Non-Pressed Paper
Dust Cap Material.....	Paper
Surround Material.....	Cloth
Basket Material	Aluminum
Magnet Material.....	Ferrite
Magnet Weight.....	80 Oz
Displacement Volume.....	0.085L

Thiele & Small Parameters

Equivalent Volume	Vas.....	15.507L
Excursion (one way)	Xmax.....	10 mm
Free Air Resonance	Fs	72.8Hz
Mechanical Factor	Qms	4.5
Electrical Factor	Qes.....	0.412
Total Factor	Qts.....	0.377
Mechanical Mass	Mms.....	55.348g
Mechanical Compliance	Cms.....	0.086 m/N
BL Factor	BL.....	14.42
Voice Coil Inductance	Le.....	17.95 mH
Cone Area	Sd.....	356.33 cm ²
CD Resistance	Re.....	3.3 ohms
Mechanical Mass w/o air	Mmd.....	47.747g

Measurements

Overall Diameter.....	10.3" / 261mm
Overall Depth.....	5.1" / 129mm
Front Mount Baffle Cutout.....	9.13" / 232mm
Mouting Depth.....	4.9" / 119mm
Motor Diameter.....	7.5" / 190mm

PRO-EXL104MB

WE LIKE IT LOUD

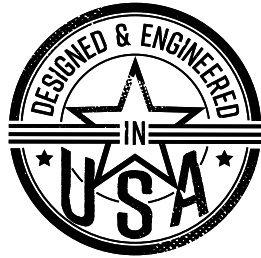

FOR MORE INFORMATION
PLEASE VISIT
DS18.COM

WE LIKE IT LOUD

The DS18 logo, featuring the letters "DS18" in a bold, stylized, italicized font. A registered trademark symbol (®) is located at the top right of the "8".

DS18[®]