

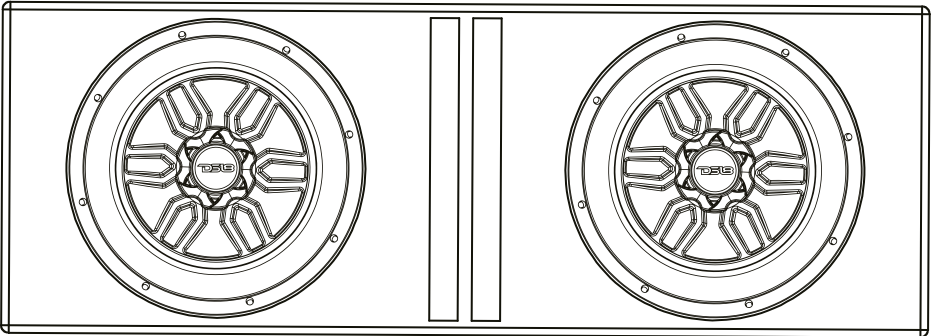

DSB[®]

OWNER'S MANUAL LSE-212A

BASS PACKAGE 2 X
SLC-MD12 IN A PORTED BOX
WITH S-1500.1 AMPLIFIER AND
4-GA AMP KIT - 1000 WATTS



SPECIFICATIONS

LS1E-212A

General

| | |
|-----------------------------------|------------|
| Speaker Size..... | 2 X 12" |
| Total Impedance..... | 2 ohms |
| Total RMS Power Handling..... | 500 watts |
| Total MAX Power Handling..... | 1000 watts |
| Sensitivity (1w/1m) | 96 db |
| Frequency Response..... | 29-250hz |
| Recommended Lo Pass Crossover.... | 80 Hz |

Subwoofer

| | |
|----------------------------------|-------------|
| Voice Coil Diameter..... | 50.8mm (2") |
| Voice Coil Former Material | Aluminum |
| Winding Material | ACCAW |
| Cone Material..... | PPI |
| Surround Material..... | Rubber |
| Basket Material..... | Steel |
| Magnet Material..... | Ferrite |
| Magnet Weight..... | 42 oz |

Box Especifications

| | |
|-------------------------|--------------|
| Port Tune..... | 35hz |
| Dust Cap Material..... | 90.6L |
| Load Configuration..... | Front Ported |
| Box Material..... | 1/2" MDF |
| Finish Material..... | Vinyl |

Measurements:

| | |
|--------------|----------------|
| Height..... | 13.78" / 350mm |
| Width..... | 38.58" / 980mm |
| Depth 1..... | 11" / 280mm |
| Depth 2..... | 14" / 356mm |

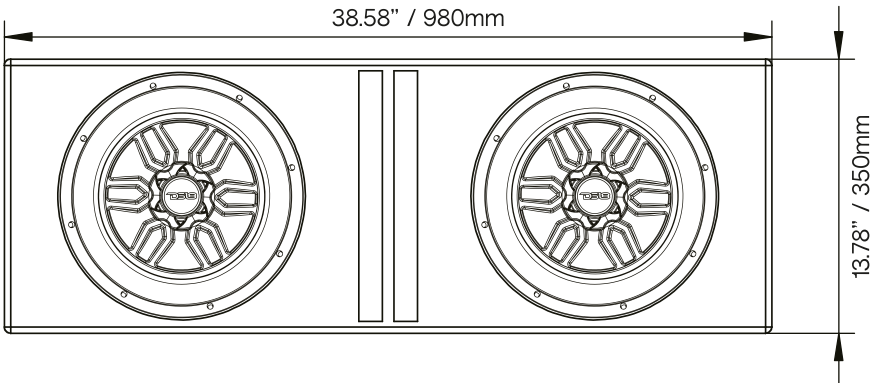

LSE-212A

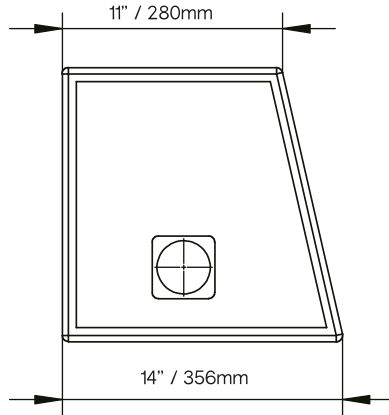

S1500.1

Amplifier

| | |
|--------------------------------|--------------------|
| Circuit Topology..... | Class AB Monoblock |
| RMS Power Output @ 2 OHMS..... | 350 watts |
| RMS Power Output @ 4 OHMS..... | 220 watts |
| Total Harmonic Distortion..... | <.3% |
| S/N Ratio Ref 1w @ 4 OHMS..... | >90 db |
| Gain Range..... | 0.2-6V |
| Crossover Range..... | 50-250hz |
| Frequency Range..... | 20Hz-500 Hz |
| Dimensions..... | 13.7" / 348mm |
| | 5.8" / 148mm |
| | 1.8" / 47.5mm |

AMPKIT 4

Installation Kit

1. AGU Fuse Holder With AGU-100A
2. 6ft. 4GA Loom Tube
3. Rubber Grommet
4. 17ft. Red Power Cable: 21mm² OD: 10mm
5. 3ft. Black Ground Cable: 21mm² OD: 10mm
6. 17ft. Red/Black Twisted RCA Cable
7. 17ft. Turn-On Cable: 20*0.15mm
8. 17ft. Red/Black Speaker Cable: 1.31mm²*2 wires OD 3.2*6.4mm

4GA ACCESSORIES SET:



INSTALLATION

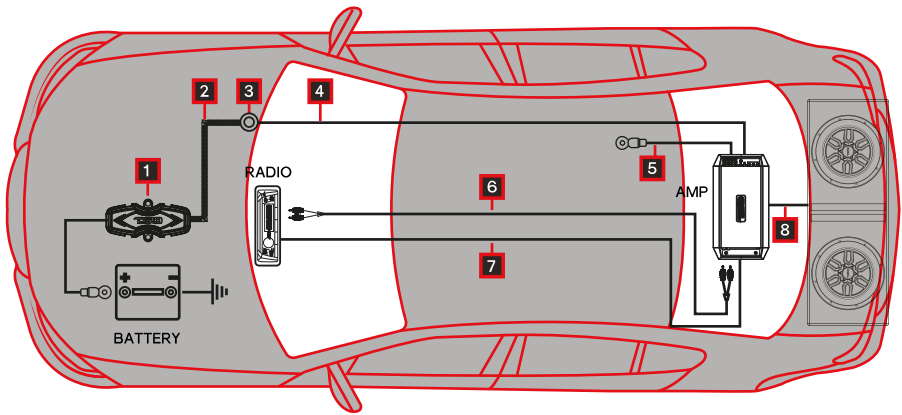

Professional installation by an authorized DS18/S Series amps dealer is highly recommended!. Otherwise, the performance of your new gear may not be satisfactory. In the event that you decide to do your own installation, please read and follow this manual carefully. Failure to do so may compromise the integrity of this product, your automobile, and possibly void the product warranty.

Amplifiers are generally mounted in the hatch/trunk area of a car or SUV, and under or behind the seat of most pick up trucks. Select a location that will provide adequate ventilation for the amplifier. Avoid mounting the amplifier with the fins facing down. The fins should be facing up, either vertically or horizontally. Secure the amplifier with the screws provided.

Before securing the amplifier, inspect the mounting location carefully to ensure that you do not drill into or damage any electrical, hydraulic, fluid or fuel lines.

INSTALLATION INSTRUCTIONS

- 1** Before you start, disconnect the negative cable from the car battery. Tape up the end so it is isolated from the battery.
- 2** Run an appropriate gauge wire from the battery to the amplifier. Plan this part of the installation carefully. This cable will carry very high current. If it should short to the body and it is not properly fused it could catch fire.

- 3** Connect the power wire to the battery using a fuse capable of the total current load of all amplifiers connected. Don't install the fuse yet. Wait until the end. Locate the fuse as close as possible to the battery. If the fuse is further than 18 inches (wire length) from the battery you should reevaluate the wire and fuse placement.
- 4** Find the closest clear metal area to the amp for a ground, sand, grind or scrape all paint and undercoating from the body and screw the ground securely in place. It is advisable to test the ground with an ohmmeter between the ground cable and the negative battery cable to insure a good low resistance connection. Some alloys used in modern cars do not offer the best ground. If you believe this is the case consult with the vehicle manufacturer.
- 5** Run the speaker wire to the speakers. It is advised that you leave some extra wire at this point. You can "clean it up" later.
- 6** If you haven't already done so, mount the amp now.
- 7** Connect the power and ground to the amplifier. Only after this step should you install the fuse at the battery.
- 8** Connect the remote wire from the head unit to the amplifier. Now is a good time to turn on the amp for the first time. Make sure it turns on properly and does not go into protection.
- 9** Connect the speaker wires to the amp and speakers (make sure the amp is off first). Make sure the polarity (+and-) is correct.
- 10** Connect the RCA's to the amp.
- 11** Double check the amplifier controls at this time. Make sure everything is set correctly for your system.
- 12** Now you're ready to play it for the first time. It is best to leave the gain all the way down at first. Start with the head until volume low and work your way up.
- 13** Now you can tune the amp. Take your time and make only one adjustment at a time. It may take some time to get the system fully adjusted. During this time the amp is drawing current from the battery. You should check the battery voltage from time to time and re-charge it if it gets low. That's it. You're done. Now have fun.

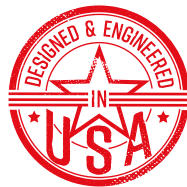

FOR MORE INFORMATION
PLEASE VISIT
DS18.COM

WE LIKE IT LOUD

The DS18 logo, featuring the letters "DS18" in a bold, stylized, italicized font. The "D" and "S" are connected, and the "18" is separate. A registered trademark symbol (®) is located to the upper right of the "8".

DS18[®]