

# DS18®

OWNER'S MANUAL

MANUAL DE USUARIO

## DXTC

2" ENCAPSULATED DOME TWEETER WITH CERAMIC  
DIAPHRAGM & EXTERNAL CROSSOVER

TWEETER DE CÚPULA ENCAPSULADA DE 2" CON  
DIAFRAGMA DE CERÁMICA Y CROSSOVER EXTERNO

4Ω



ENGLISH | ESPAÑOL



## **2" ENCAPSULATED DOME TWEETER WITH CERAMIC DIAPHRAGM & EXTERNAL CROSSOVER**

### **TWEETER DE CÚPULA ENCAPSULADA DE 2" CON DIAFRAGMA DE CERÁMICA Y CROSSOVER EXTERNO**

#### **SPECIFICATIONS / ESPECIFICACIONES**

**Nominal Diameter / Diámetro Nominal**.....**2" / 51mm**

**Nominal Impedance / Impedancia Nominal** ..... **4 ohms**

**AES Power Handling / Manejo de Potencia AES**.....**25W**

**Program Power Handling / Manejo de Potencia del Programa** .....**50W**

**Peak Power Handling / Manejo de Potencia Máxima** ..... **100W**

**Sensitivity (1w/1m) / Sensibilidad (1w/1m)** .....**88dB**

**Frequency Response / Respuesta de Frecuencia**..... **250Hz-20KHz**

**Recommended HI Pass Crossover**.....**500Hz**

Crossover Paso alto Recomendado

**Pair or Single** ..... **Pair Tweeter, Pair Crossover**

Par o Unidad..... Par Tweeter, Par Crossover

#### **BODY & FEATURES / CUERPO & CARACTERÍSTICAS**

**Crossover (Bass Blocker)** ..... **External / 12dB/Oct**

Crossover (bloqueador de graves) ..... Externo / 12dB / Oct

**Body Material / Material del Cuerpo** ..... **CNC Aluminum / Aluminio**

**Body Color / Material del Cuerpo** ..... **Black / Negro**

**Faceplate Color / Material del Cuerpo** ..... **Black / Negro**

## MOTOR / MOTOR

Voice Coil Diameter / Diámetro de la Bobina de Voz ..... 1" / 25.4mm

Voice Coil Former Material ..... Polyimide / Poliimida

Material Interior de Bobina Móvil

Winding Material / Material de Bobinado ..... Aluminum / Aluminio

Diaphragm Material / Material del Diafragma ..... Ceramic / Cerámica

Magnet Material / Material del Imán..... Neodymium / Neodimio

Magnet Size / Tamaño del Imán ..... 25mm / 0.650z

## MEASUREMENTS (TWEETER) / MEDIDAS (TWEETER)

Overall Diameter / Diámetro Total ..... 2.36" / 60mm

Overall Depth / Profundidad Total ..... 2" / 52mm

Front Mount Baffle Cutout / Corte del Orificio de Montaje ..... 2" / 52mm

Mounting Depth / Profundidad de Montaje ..... 1.4" / 36mm

## MEASUREMENTS (CROSSOVER) / MEDIDAS (CROSSOVER)

Overall Length / Longitud total ..... 3.15" / 78mm

Overall Width / Ancho promedio ..... 1.95" / 49.5mm

Overall Height / Altura total ..... 1.14" / 29mm

*WE LIKE IT LOUD*

# DXTC

INSTALLATION / INSTALACIÓN

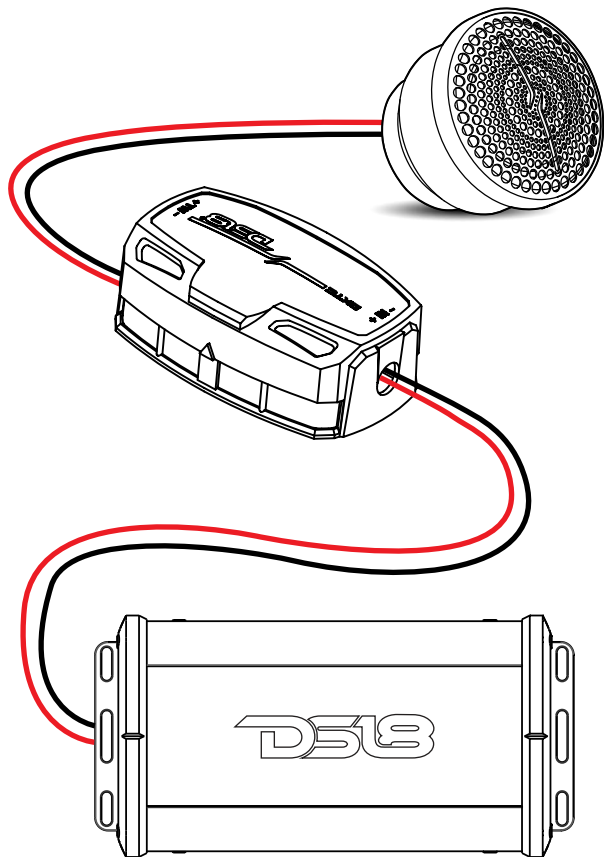

**Amplifier not included**  
Amplificador no incluido

MEASUREMENTS / MEDICIONES

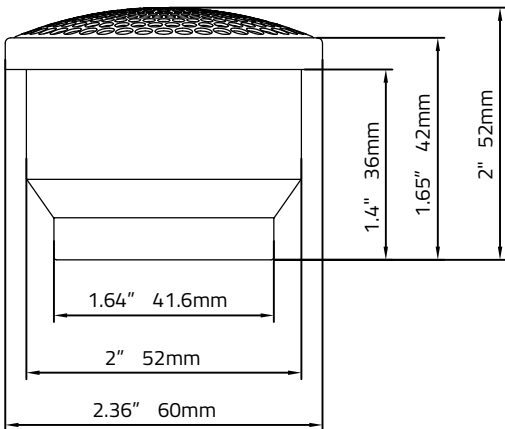
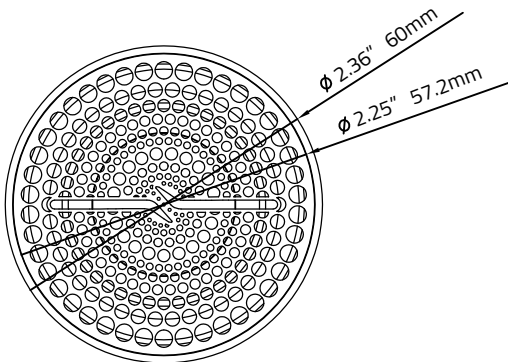

# DXTC

MEASUREMENTS / MEDICIONES

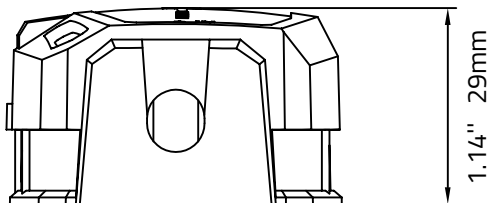
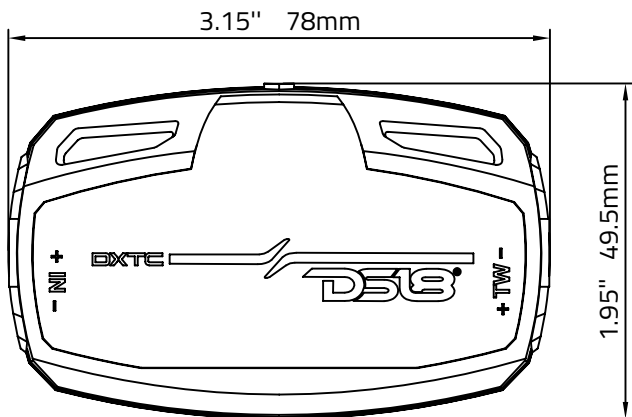

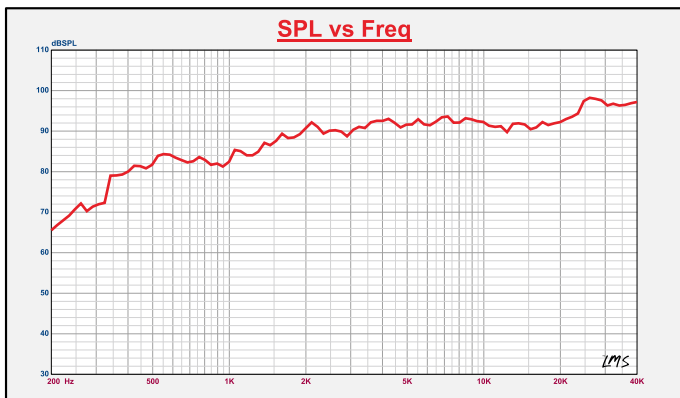

## WARRANTY

Please visit our website [DS18.com](http://DS18.com) for more information on our warranty policy.

We reserve the right to change products and specifications at any time without notice.

Images may or may not include optional equipment.

## GARANTÍA

Visita nuestra página web [DS18.com](http://DS18.com) para obtener más información sobre nuestra garantía.

Nos reservamos el derecho de cambiar productos y especificaciones en cualquier momento sin previo aviso. Las imágenes pueden incluir o no equipo opcional.



### WARNING:

Cancer and Reproductive Harm.  
[www.P65Warning.ca.gov](http://www.P65Warning.ca.gov)



### ADVERTENCIA:

Cáncer y Daño Reproductivo.  
[www.P65Warning.ca.gov](http://www.P65Warning.ca.gov)



FOR MORE INFORMATION  
PLEASE VISIT  
[DS18.COM](http://DS18.COM)

*WE LIKE IT LOUD*